

National Gallery of Art

Washington, D.C. 20565

Official Business
Penalty for Private Use, \$300

Postage
and Fees
Paid
National
Gallery of
Art



Third Class Bulk Rate
Return Postage Guaranteed

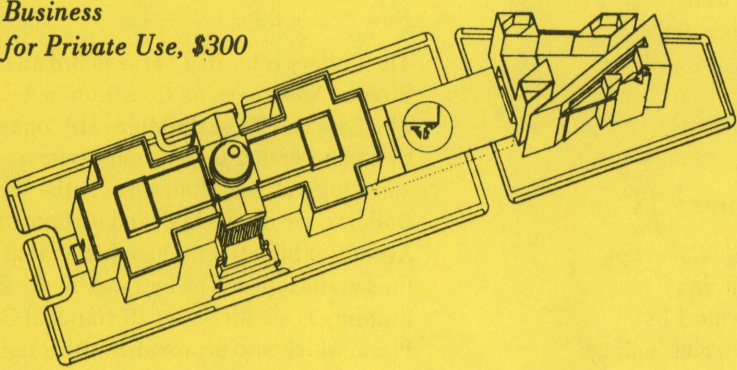

CALENDAR OF EVENTS

December 1980

Painting of the Week

MONDAY, December 1 through SUNDAY, December 7

Goya
The Marquesa de Pontejos
(Andrew W. Mellon Collection)

Tues. through Sat. 12:00 & 2:00; Sun. 3:30 & 6:00

West Building
Gallery 37



Tours

Images of Alexander from Antiquity to the Present
Tues. through Sat. 1:00 (Not on Sunday)
East Building
Auditorium

Introduction to the West Building's Collection
Mon. through Sat. 11:00
Sun. 1:00
West Building
Rotunda

Introduction to the East Building's Collection
Mon. through Sat. 3:00
Sun. 5:00
East Building
Ground Floor Lobby

Films

American Art in the Sixties
(57 min.)
Tues. through Sat. 12:00
Sun. 1:00

East Building
Auditorium



Sunday Lectures

Guido Reni and the Pope—Roman Political Intrigue in 1627

Speaker:
D. Stephen Pepper
Art Historian, Author,
and Lecturer
New York City

Sunday 4:00

East Building
Auditorium

Concerts

Horatio Miller, *Pianist*

West Building
East Garden Court 7:00

MONDAY, December 8 through SUNDAY, December 14

Poussin
Holy Family on the Steps
(Samuel H. Kress Collection)

Tues. through Sat. 12:00 & 2:00; Sun. 3:30 & 6:00

West Building
Gallery 52

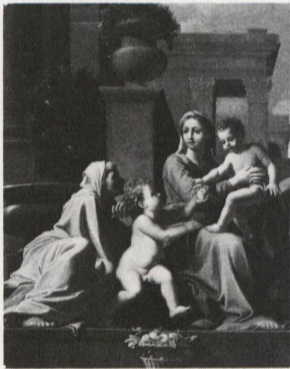

Macedonia in the Age of Alexander
Tues. through Sat. 1:00 (Not on Sunday)
East Building
Auditorium

Introduction to the West Building's Collection
Mon. through Sat. 11:00
Sun. 1:00
West Building
Rotunda

Introduction to the East Building's Collection
Mon. through Sat. 3:00
Sun. 5:00
East Building
Ground Floor Lobby

Robert Rauschenberg: Retrospective (45 min.)
Tues. through Sat. 12:00
Sun. 1:00

East Building
Auditorium

Picasso: The Saltimbanques

Speaker:
E. A. Carmean, Jr.
Curator of Twentieth-Century Art
National Gallery of Art

Sunday 4:00

East Building
Auditorium



Nicholas Anderson
Cellist
Jacqueline Divenyi
Pianist

West Building
East Garden Court 7:00

MONDAY, December 15 through SUNDAY, December 21

Giorgione
The Adoration of the Shepherds
(Samuel H. Kress Collection)

Tues. through Sat. 12:00 & 2:00; Sun. 3:30 & 6:00

West Building
Gallery 21



Alexander and Hellenistic Culture
Tues. through Sat. 1:00 (Not on Sunday)
East Building
Auditorium

Introduction to the West Building's Collection
Mon. through Sat. 11:00
Sun. 1:00
West Building
Rotunda

Introduction to the East Building's Collection
Mon. through Sat. 3:00
Sun. 5:00
East Building
Ground Floor Lobby

George Segal
(58 min.)
Tues. through Sat. 12:00
Sun. 1:00

Les Enfants du Paradis
(English subtitles)
(188 min.)
Sat. 2:15

East Building
Auditorium

SUNDAY FILM

Les Enfants du Paradis
(English subtitles)
(188 min.)

Sunday 4:00

East Building
Auditorium



National Gallery
Orchestra
Richard Bales, *Conductor*
William Montgomery
Flutist

West Building
East Garden Court 7:00

MONDAY, December 22 through SUNDAY, December 28

Isenbrant
The Adoration of the Shepherds
(Ailsa Mellon Bruce Fund)

Tues., Wed., Fri., & Sat. 12:00 & 2:00
Sun. 3:30 & 6:00

West Building
Gallery 41A

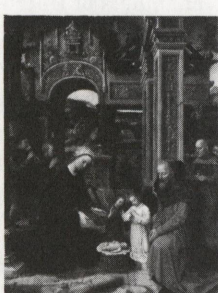

Introduction to the West Building's Collection
Mon. through Wed., Fri., & Sat. 11:00; Sun. 1:00
West Building
Rotunda

Introduction to the East Building's Collection
Mon. through Wed., Fri., & Sat. 1:00 & 3:00
Sun. 2:30 & 5:00
East Building
Ground Floor Lobby

Catlin (6 min.) and
The Shadow Catcher
(88 min.)
Tues., Wed., & Fri. 12:30; Sun. 1:00

Les Enfants du Paradis
(English subtitles)
(188 min.)
Sat. 12:30

East Building
Auditorium

Picasso's Three Musicians, Maskers, Artists, and Friends

Speaker:
Theodore Reff
Professor of Art History
Columbia University
New York

Sunday 4:00

East Building
Auditorium

Margo Collins, *Violinist*
Frank Conlon, *Pianist*

West Building
East Garden Court 7:00

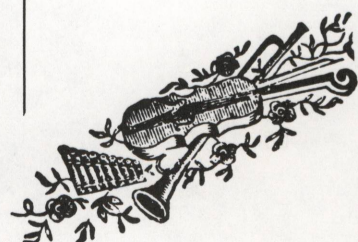

National Gallery of Art

Washington, D.C. 20565

The telephone number for all offices is
(202) 737-4215.

Closing December 31

American Indian Life: Paintings by George Catlin consists of 53 finished oil sketches by this well-known 19th-century painter of the American Indian. Powerful portraits, scenes of ceremonies, hunting, and other daily activities, as well as landscapes, are included in the exhibition.

Extended through January 11

The Morton G. Neumann Family Collection includes approximately 140 paintings, sculpture, drawings, and watercolors by major 20th-century artists from an outstanding private Chicago collection.

Gallery Hours: The Gallery is open 10 a.m. to 5 p.m. Monday through Saturday. Sunday hours remain the same throughout the year: 12 noon to 9 p.m. Closed Christmas Day and New Year's Day.

The Gallery is located between 3rd and 7th Streets, Northwest, on Constitution Avenue. The East and West Buildings are connected by an all-weather underground passage with a moving walkway. Entrances to the West Building are on the Mall and on Constitution Avenue at 6th Street, which has a ramp for the handicapped. The entrance to the East Building is on 4th Street off National Gallery Plaza, which also is provided with a ramp for the handicapped.

EXHIBITIONS

December 1980

Picasso: The Saltimbanques

December 14 through
March 15, 1981
Mezzanine Level
East Building

This exhibition includes a great variety of works all related to the National Gallery's painting *Family of Saltimbanques*, the largest and most ambitious project of Picasso's early career. The painting's theme of vagabond performers and their isolated lives obsessed Picasso and became one of the most persistent in his oeuvre. It dominated his work during the fifteen months from late 1904 to early 1906, when he moved from expressing the deep melancholy of his Blue Period to developing lighter, less tragic themes.

Paintings, drawings, prints, and sculpture by Picasso, as well as examples by Watteau, Daumier, Manet, and Seurat, will be on view to illustrate the related depictions of the Harlequin, jester, and Columbine from their origins in the commedia dell'arte of the seventeenth century to the circus figures of Picasso's day. Public and private collections in the United States, Europe, and Japan have lent to the exhibition.

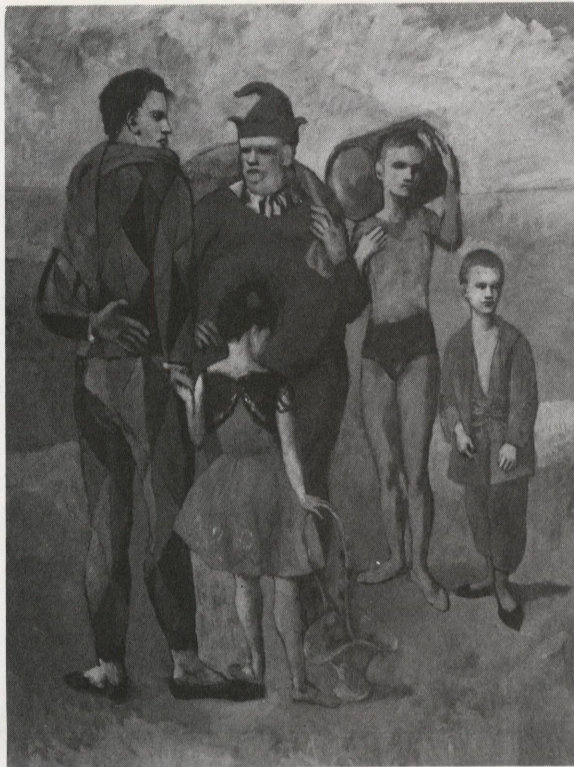

Family of Saltimbanques (detail). PICASSO
Chester Dale Collection
National Gallery of Art, Washington

The exhibition has been organized by the Gallery to mark the centenary of Picasso's birth in 1881. During art-historical research and technical investigation by x-ray and other means for the exhibition, a major painting by Picasso, which was previously believed to be lost, came to light. Entitled *Circus Family*, the composition is a preliminary layer beneath the surface of *Family of Saltimbanques*. A second composition, *Two Acrobats*, unknown until now, was also discovered as an intermediate layer on the same canvas. X-radiographs from this technical study will also be on view.

Lectures and Films: On Sunday, December 14, E. A. Carmean, Jr., the Gallery's curator of twentieth-century art and organizer of the exhibition, will speak on the theme of the saltimbanques in Picasso's art. And, on Sunday, December 28, Theodore Reff, professor of art history at Columbia University, will deliver a lecture entitled *Picasso's Three Musicians, Maskers, Artists, and Friends*. The classic 1943 film on the street performers of the Paris theater district, *Les Enfants du Paradis*, will be shown in conjunction with the exhibition. (Check listings for details.)

The Search for Alexander

Through April 5, 1981
Concourse level
East Building

This major international loan exhibition of Greek art from the time of Alexander the Great (356-323 B.C.) and the Hellenistic era he introduced continues its U.S. premiere at the Gallery before beginning a cross-country tour of American cities. For the first time in the United States, a selection of 175 objects has been assembled from Greek, European, and American public and private collections to show the expert craftsmanship and supreme artistry in 4th- and 3rd-century B.C. metalwork, sculpture, jewelry, and terracotta sculpture from the region of northern Greece known as Macedonia. The approximately 100 pieces from Greek museums have never been seen outside that country before.

The exhibition is organized to lead the viewer in a search for Alexander backward in time, through the imagery of his fame into antiquity and the Macedonian art of Alexander's own time and place. Among the highlights of the exhibition are gold and silver objects—including a wreath of oak leaves, a gilded silver diadem, armor, a gold chest, and



Bronze krater
found in Grave Beta, Derveni
Archaeological Museum of Thessalonike
Copyright © 1980 by the Greek Ministry
of Culture and Sciences

vessels—from the royal tomb at Vergina discovered in 1977 by Greek archaeologist Manolis Andronikos, who attributed this tomb to Philip II of Macedon, Alexander's father. Other important pieces are small ivory portraits of Philip and Alexander, also from the Vergina site, and a large bronze krater with bacchic scenes found at Derveni, in northern Greece.

During crowded times the Gallery is issuing free passes for admission to the exhibition to minimize the length of time visitors must wait in line, and to avoid overcrowding in the show. Passes may be obtained for the current day only on a first-come, first-served basis. The passes, which are distributed at the entrance to the show, allow admission to the exhibition at any time during designated half-hour intervals, but visitors may remain in the exhibition as long as they wish.

Tours: Beginning December 2 for three weeks, the Tours of the Week will be in the form of special auditorium lectures in conjunction with the exhibition. Illustrated with slides of objects in the show and given by members of the Gallery's education department, these talks will be held Tuesdays through Saturdays at 1 p.m. in the East Building Auditorium.

Gods, Saints and Heroes: Dutch Painting in the Age of Rembrandt

Through January 4, 1981
Galleries 43-51
West Building



Vertumnus and Pomona. MOREELSE
Rotterdam, Boymans-van Beuningen Museum

Eighty-five paintings have been selected from European and American public and private collections for this exhibition of 17th-century Dutch history painting. Paintings of biblical, mythological, and allegorical scenes were referred to in the 17th century as "history painting," and theorists of the time regarded it as the highest achievement of art. This aspect of Dutch painting has been neglected for well over a century. Modern critics have emphasized the remarkably naturalistic qualities of Dutch art and the degree to which Dutch culture differed from that in other countries. Although these history paintings exhibit the same realism found in Dutch landscapes, still lifes, and portraits, they demonstrate a far more international and intellectual aspect of Dutch culture than generally recognized.

Included are masterpieces from council chambers of Dutch town halls that have never before been part of a major exhibition and five major works by Rembrandt, including *Belshazzar's Feast* and *The Denial of St. Peter*. Other artists represented are Jan Vermeer, Hendrick ter Brugghen, Jan Steen, Hendrick Goltzius, Pieter Lastman, Abraham Bloemaert, Jan Lievens, Frans Post, Nicolaes Berchem, Jan de Braij, Gerard Lairesse, and Aert de Gelder.